

# OK-VISE

## FIXTURING CONCEPT

 MADE IN FINLAND



Low-Profile Clamps



Multi-Rail System



Blank System

**Precision that holds – Performance that lasts**  
Based on OK-VISE clamping method

# OK-VISE FIXTURING CONCEPT



4\_\_ What is Fixturing concept

## LOW PROFILE CLAMPS

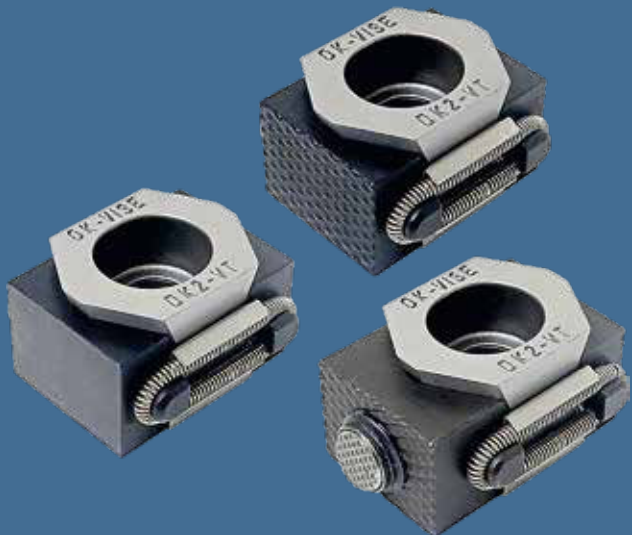

- 6\_\_ The core of any workholding system
- 7\_\_ Different jaw options
- 10\_\_ Pull down models
- 11\_\_ Special models & Accessories
- 12\_\_ Jaw combinations
- 13\_\_ Clamp forces

## MULTI-RAIL SYSTEM

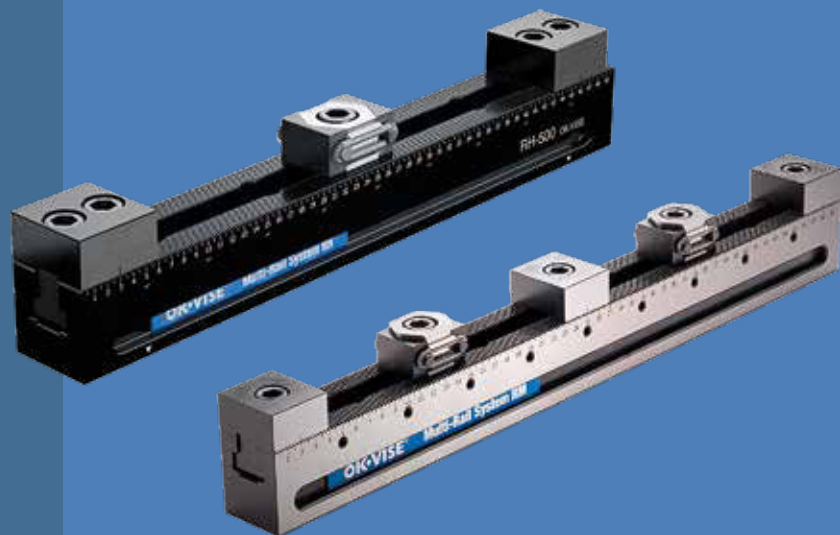

- 14\_\_ Quick and easy modular rail system
- 17\_\_ Multi-Rail applications ( RM, RL and RH)
- 21\_\_ Floating units
- 22\_\_ Grid system

## AUTOMATED CLAMPING

- 26\_\_ Method of automated clamping
- 27\_\_ ELVA, Electrical clamping

## TOOLING BLOCKS



## BLANK SYSTEM

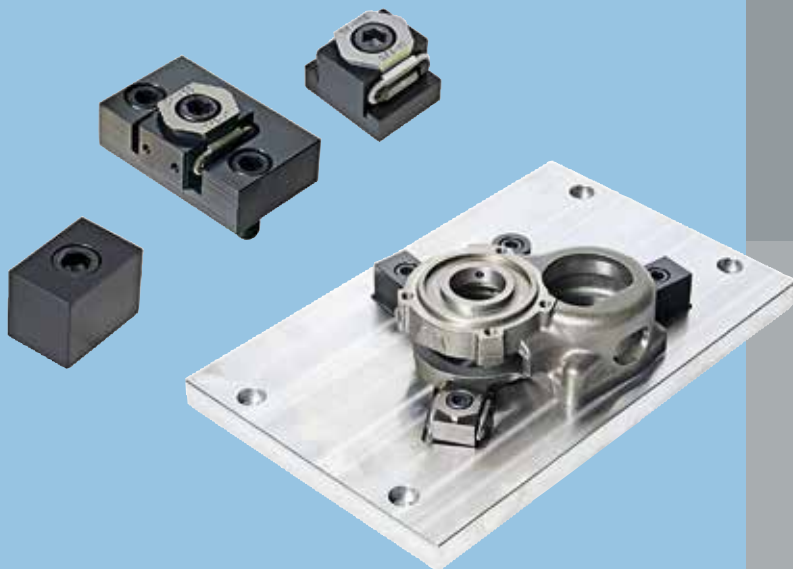

23\_\_How does OK-VISE Blank system works

## Tips for building a fixture!

24

## Modular vs. dedicated fixturing

25

## OK-VISE ZERO POINT SYSTEM

29

## COMPANY

30\_\_The early days

31\_\_ OK-VISE today

# OK-VISE® FIXTURING CONCEPT

## What is Fixturing Concept?

The OK-VISE Fixturing Concept features a range of components that are suitable for clamping different workpiece types, sizes, and materials on all types of workholding platforms and machining centers.

**A wide selection of information & the latest updates**  
[www.ok-vise.com](http://www.ok-vise.com)

Whether there's a need for product-specific fixtures that are quick and easy to implement for production, or an idea for fixture savings utilizing a high-precision and flexible modular fixture system, OK-VISE has got it covered.

**The fixturing concept is based on a few basic functions**

**Clamps:** All systems are based on the original Low-Profile clamp

**Locating components:** Stoppers, side guides and parallels

**Floating elements:** For extra support

All of our Fixturing Concept systems are based on the same functions. Additionally, we offer automated clamping solutions, tooling blocks, the OK-LOCK zero-point system and the Digiforce force verification system.

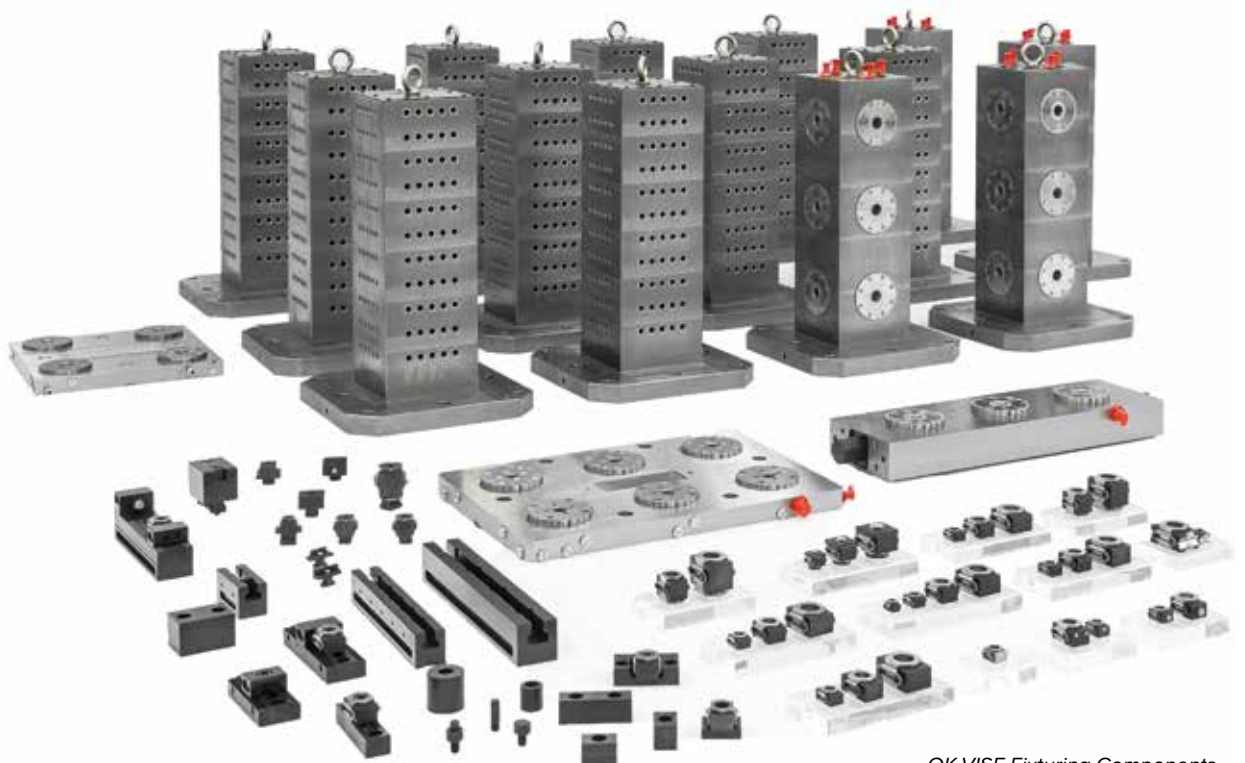

OK-VISE Fixturing Components

## Our value proposition for customers

At OK-VISE, we bring decades of experience to workpiece clamping. Leveraging our professional skills and a selection of high-quality components, we can help the customer to optimize their manufacturing processes, improve efficiency, and achieve higher precision in their workpiece clamping operations.

Our fixturing concept offers a complete solution, providing an easy and flexible clamping environment on which customers can rely in the future.

### OK-VISE Fixturing concept



## OK-VISE's user experiences:

We have been using OK-VISE's low-profile clamps already 40 years now. They are very durable and accurate products and have proved extremely successful in use. OK-VISE's fixturing system is very fast in use, extremely flexible, accurate, ideal for our production needs as well as cost efficient.

*Production Manager,  
Kytola Instruments Oy*

OK-VISE's service has been very good. They've been very responsive to our problems and our issues. If we've had a thought or a new idea, they've developed it to suit us even better.

*CEO, Ljungby CNC Teknik AB*



A complete fixturing solution for customer's FMS





# LOW PROFILE CLAMPS

## The core of any workholding system

Low-profile clamps can be used either manually (as shown in the picture) or automatically. The utilization of OK-VICE Low Profile clamps offers an effective and time-saving solution by enabling full workspace utilization due to their low profile and small footprint. Efficient use of the machinable area leads to savings in tool changes, reduces operator interventions, and ultimately extends cycle times while minimizing machine stop times.

One of the advantages of low-profile clamps over traditional vises is their ability to clamp several workpieces simultaneously. The outer surface of the wedges is precision-ground, ensuring an exact ratio of torque and force. This precision and accuracy in clamping guarantee the best possible result for machined parts.

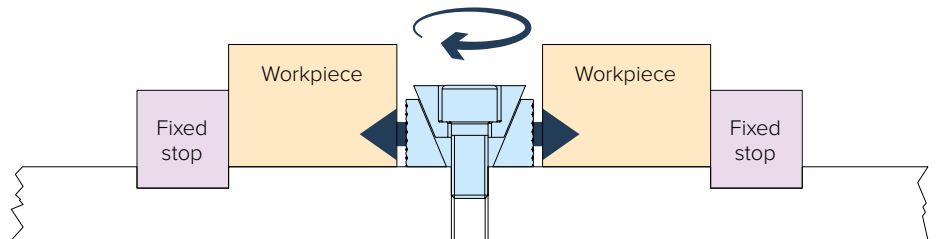

## Full 10 year warranty

OK-Vise Oy has been a leading manufacturer of wedgeclamps for over 40 years. Some of our first customers have been using the same clamps for all this time and still use them on a daily basis. Based on this experience, and after conducting extensive tests with our clamps, we are prepared to give a full 10 year warranty for the quality of the raw material and craftsmanship of all wedge and jaw parts of our low-profile clamps, excluding the blackening, springs, and sideplates.



## Absolute stability

The key feature of the OK-VICE low-profile clamp is its cross-wedge structure in both the horizontal and vertical planes, which means that the clamp is locked firmly in every direction as it is tightened down. This eliminates all possibilities of play.

## Extreme clamping force

Despite their small size, these low-profile clamps possess a high clamping force of up to 150 kN. They are lightweight, easy to use, and can be effortlessly transferred from one machine or setup to another as required. Single-wedge low-profile clamps are available in sizes M5, M8, M12, and M16, depending on the model.



A

B

D

F

# CLAMP MODELS

## Different jaw options

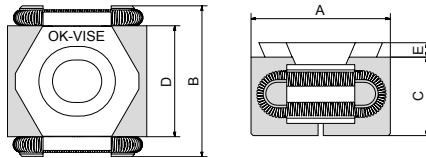

### SMOOTH MODEL

Specifically engineered to securely hold your workpiece without leaving any visible marks or scratches.

Made with high-quality materials, the clamp is built to last, saving you money and time. The clamp is easy to install and adjust, allowing you to secure your workpiece quickly and efficiently with precision.

Model	A min-opt max	B	C	D	E	Socket head screw DIN 912	Max pressing force (kN)	Hardness of jaws (HRC)
<b>BK2-VT-S</b>	27-29-31	29	15	21	2,5	M8x20	25	48-52
<b>DK2-VT-S</b>	42-45-49	41	22	30	4	M12x30	65	
<b>DK2-VTI-S</b>	1,65-1,77-1,92	1,61	0,86	1,18	0,15	½"-1¼"	65	
<b>FK2-VT-S</b>	57-60-64	56	29	42	5	M16X40	110	

### TUNGSTEN CARBIDE COATED MODEL

Required holding force with less clamping force whilst preventing distortions of the workpiece while clamping.

These clamps are an excellent choice when:

- No visible clamping marks in the workpiece, but high friction is still needed.
- Thin-walled workpieces are being machined.

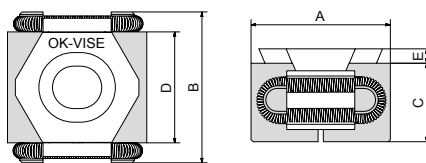

Model	A min-opt-max	B	C	D	E	Socket head screw DIN 912	Max pressing force (kN)	Hardness of jaws (HRC)
<b>AK2-VT-DO</b>	20-23-25	22	11	15	4,2	M5x25	10	60
<b>BK2-VT-D</b>	27-29-31	29	15	21	2,5	M8x20	25	
<b>DK2-VT-D</b>	42-45-49	41	22	30	4	M12x30	65	
<b>DK2-VTI-D*</b>	1,65-1,77-1,92	1,61	0,86	1,18	0,15	½"-1¼"	65	

\* inch model

### SERRATED MODEL

The serrated jaw model creates high friction between workpiece and the clamp, ensuring consistent and reliable clamping.

The hardness of the jaw is 48-52 HRC.

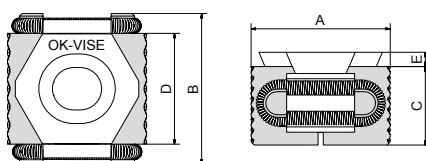

Model	A min-opt max	B	C	D	E	Socket head screw DIN 912	Max pressing force (kN)	Hardness of jaws (HRC)
<b>BK2-VT</b>	27-29-31	29	15	21	2,5	M8x20	25	48-52
<b>DK2-VT</b>	42-45-49	41	22	30	4	M12x30	65	
<b>DK2-VTI</b>	1,65-1,77-1,92	1,61	0,86	1,18	0,15	½"-1¼"	65	
<b>FK2-VT</b>	57-61-65	56	29	42	5	M16X40	110	

# CLAMP MODELS

## Different jaw options

### KNIFE EDGE GRIP MODEL

Our knife edge grip low-profile clamps possess one or two serrated knife edge jaws.

This model works best on soft workpieces, like aluminum or plastic.

The design of the product enables gripping the workpiece from a low position, allowing for more machinable surface area.

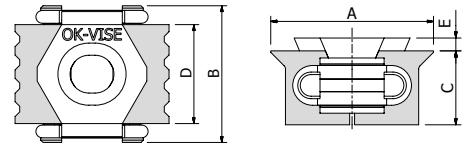

Model	A min-opt max	B	C	D	E	Socket head screw DIN 912	Max pressing force (kN)	Hardness of jaws (HRC)
<b>BK2-VT-SG</b>	30-31,5-34	29	15	21	2,5	M8x20	25	48
<b>BK2-VT-G</b>	42-45-49	29	15	21	2,5	M8x20	25	
<b>DK2-VT-SG</b>	46,5-50-53	41	22	30	4	M12x30	65	
<b>DK2-VT-G</b>	57-61-65	41	22	30	4	M12x30	65	

SG = one jaw is knife edge, the other smooth

G = both jaws are knife edge

### PIN GRIP MODEL

The pin grip models are equipped with n hard steel pins (Gn = 1...3 pcs), which increases the friction between the workpiece and the jaw.

When the friction offered by serrated jaws is not enough for your application, the pin grip model is the ideal solution.

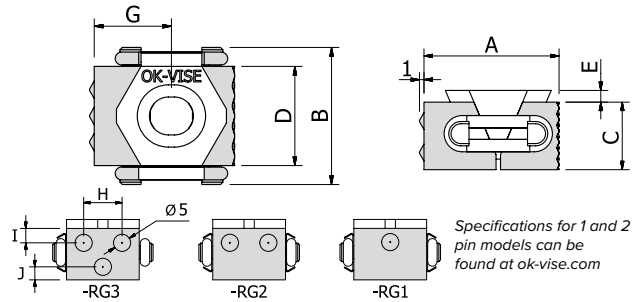

Specifications for 1 and 2 pin models can be found at [ok-vice.com](http://ok-vice.com)

Model	A min-opt-max	B	C	D	E	H	I	J	Socket head screw DIN 912	Max pressing force (kN)	Hardness of jaws (HRC)
<b>BK2-VT-G3</b>	33-35-37	29	15	21	2,5	11	4	4	M8x20	25	60
<b>BK2-VT-RG3</b>	30-32-34	29	15	21	2,5	11	4	4	M8x20	25	
<b>DK2-VT-G3</b>	52-55-59	41	22	30	5	20	5	5	M12x30	65	
<b>DK2-VT-RG3</b>	47-50-54	41	22	30	5	20	5	5	M12x30	65	
<b>FK2-VT-G3</b>	67-70-75	59	29	42	5	24	5	7	M16x40	110	
<b>FK2-VT-RG3</b>	62-65-70	59	29	42	5	24	5	7	M16x40	110	

G3 = one jaw is pin grip, the other serrated, RG3 = both jaws are pin grip jaws

### ADDITIONAL PIECE MODEL

Additional piece models have machined female threading (M5) for socket head screws on the side of the jaw, making it quick and easy to use various additional pieces which can also be machined into irregular shapes.

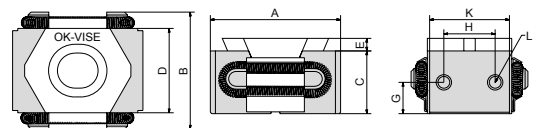

Model	A min-opt max	B	C	D	E	G	H	K	L	Socket head screw DIN 912	Max pressing force (kN)	Hardness of jaws (HRC)
<b>BK2-VT-T</b>	33-35-37	29	15	21	2,5	7,5	12	21	M5	M8x20	22	30-34
<b>DK2-VT-T</b>	46-49-53	41	22	30	4	11	18	28	M5	M12x30	65	
<b>DK2-VT-T</b>	1,81-1,92-2,08	1,61	0,86	1,18	0,15	0,43	0,7	1,1	M5	½"-1¼"	65	
<b>FK2-VT-T</b>	61-65-69	56	29	42	5	14,5	26	40	M5	M16x40	110	

There are several sizes of additional pieces available, mostly made from aluminum but also from steel.

# CLAMP MODELS

## Different jaw options

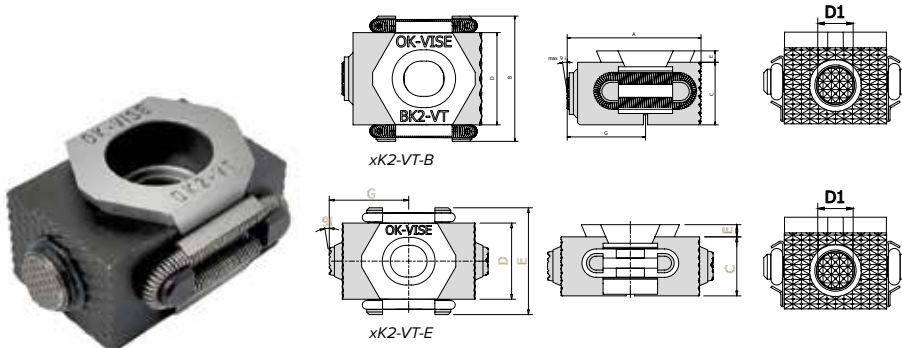

### SELF-ADJUSTABLE MODEL

Self-adjustable clamp model is a great option when the workpiece has irregular shapes.

These clamps have a self-adjustable ball pressure screw inserted into a clamp jaw. The ball bearing at the end is made of steel and equipped with torsion protection, allowing the ball to self-adjust up to 9 degrees.

Model	A min-opt max	B	C	D	D1	E	Socket head screw DIN 912	Max pressing force (kN)	Hardness of jaws (HRC)
BK2-VT-E	39-41-43	29	15	21	7,2	2,5	M8x20	22	30-34
DK2-VT-E	62-65-69	41	22	30	10,7	4	M12x30	55	
DK2-VT-E	2,44-2,56-2,72	1,61	0,86	1,18	0,42	0,15	½"-1 ¼"	55	
BK2-VT-B	33-35-37	29	15	21	7,2	2,5	M8x20	22	
DK2-VT-B	52-55-59	41	22	30	10,7	4	M12x30	55	

E = both jaws are self-adjustable

B = one jaw is self adjustable and the other is serrated

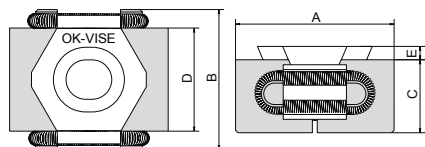

### MACHINABLE MODEL

These low-profile clamps come with extended jaws and can be machined to suit the geometry of the workpiece.

The smallest model can be machined up to 3 mm and the larger ones up to 5 mm:

- B-size clamp = 3 mm
- D- and F-size clamps = 5 mm

Model	A min-opt-max	B	C	D	E	Socket head screw DIN 912	Max pressing force (kN)	Hardness of jaws (HRC)
BK2-VT+3	33-35-37	29	15	21	2,5	M8x20	22	30-34
DK2-VT+5	52-55-59	41	22	30	4	M12x30	55	
FK2-VT+5	67-70-75	56	29	42	5	M16x40	100	

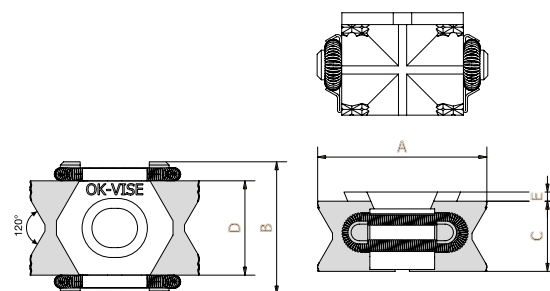
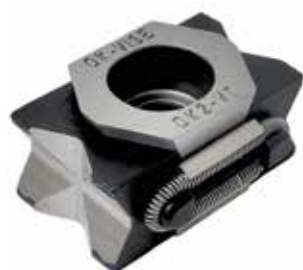

### V-SLOT CROSSED MODEL

This model is ideal for clamping rods, pins, and disks.

Low-profile clamps with cross V-slot are used for machining of the cylindrical workpieces. The clamps enable workpieces to be placed in both the horizontal and vertical planes.

Model	A min-opt max	B	C	D	E	N	Socket head screw DIN 912	Max pressing force (kN)	Hardness of jaws (HRC)
BK2-VT-C	33-35-37	29	15	21	2,5	3	M8x20	25	30-34
DK2-VT-C	52-55-59	41	22	30	4	5	M12x30	55	
DK2-VT-C	2,04-2,16-2,31	1,61	0,86	1,18	0,15	0,2	½"-1 ¼"	55	
FK2-VT-C	67-70-75	56	29	42	5	5	M16x40	100	

# CLAMP MODELS

## Pull-Down models

### SINGLE-WEDGE MODEL

The OK Vise single-wedge pull-down clamp design is a standard single-wedge clamp and combined with a pull-down set.

The major differences of single-wedge pull-down clamp when compared with double wedge pull-down clamps are:

- There are more variations of jaw types and clamp sizes.
- The angle of the movement is steeper.
- It is easy to test fixture with and without pull-down property.

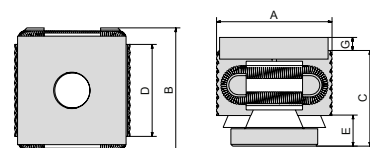
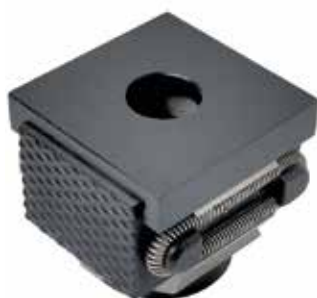

Model	A min-opt-max	B	C	D	E	G	Socket head screw DIN 912	Max pressing force (kN)	Hardness of jaws (HRC)
BK2-VT-PD	27-29-31	29	22	21	7	3	M8x20	25	48-52
DK2-VT-PD	42-45-49	41	32	30	10	4	M12x60	65	

### DOUBLE-WEDGE MODEL

Pull-down workholding clamps generate pull-down action pressing work-pieces down onto the fixture base, as an alternative to applying sideways force to the jaw on the fixture base.

The F-size model with its extreme clamping force of 150 kN is the strongest model in our range of low-profile clamps.

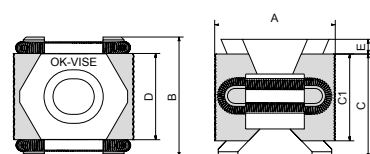

	Model	A min-opt-max	B	C	C1	D	E	Socket head screw DIN 912	Max pressing force (kN)	Hardness of jaws (HRC)
SMOOTH JAW	DK2-WT-S	41-45-48	41	36	30	30	5	M12x40	90	48-52
	DK2-WTI-S	1,64-1,77-1,88	1,61	1,41	1,18	1,18	0,19	½"-1 3/4"	90	
	FK2-WT-S	58-61-66	56	50	42	42	5	M16x40	150	
SERRATED JAW	DK2-WT	42-46-49	41	36	30	30	5	M12x40	90	48-52
	DK2-WTI	1,61-1,81-1,92	1,61	1,41	1,18	1,18	0,19	½"-1 3/4"	90	
	FK2-WT	58-61-66	56	50	42	42	5	M16x40	150	

### THE OPERATION

Create additional force to push the work piece towards the fixture base whereas in most common clamp models, the wedge prevents the jaw from lifting up while clamping and machining (hold-down).

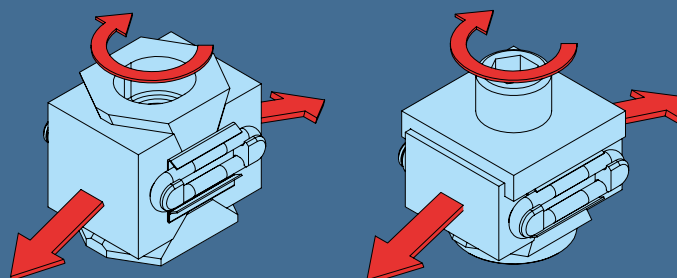

# CLAMP MODELS

## Special models

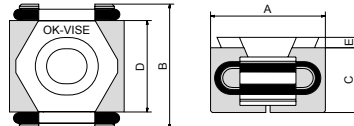

### STAINLESS STEEL MODEL

The high quality stainless steel low-profile clamp is designed to meet the demands of wire EDM applications. It also works effectively in welding applications.

This model is available with a smooth jaw configuration.

Model	A min-opt-max	B	C	D	E	Socket head screw DIN 912	Max pressing force (kN)	Hardness of jaws (HRC)
<b>BK2-VT-SS</b>	27-29-31	29	15	21	2,5	M8x20	25	48-52

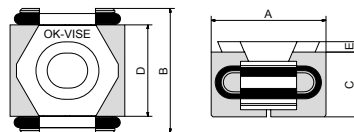

### ECONOMY MODEL

The Cost-Efficient Choice.

Economy workholding clamp models, only the bottom of the jaw is ground. Economy models are used in regular workholding when ultraprecision is not required.

They are made of the same raw materials as other models, and the bottom of the jaws are ground for precise positioning on the fixture base.

Model	A min-opt-max	B	C	D	E	Socket head screw DIN 912	Max pressing force (kN)	Hardness of jaws (HRC)
<b>AK2-VT-SO</b>	20-23-25	22	11	15	4,2	M5x25	10	48-52
<b>BK2-VT-O</b>	27-30-33	29	15	21	4	M8x20	15	
<b>BK2-VT-SO</b>	27-30-33	29	15	21	4	M8x20	15	

## ACCESSORIES

### ADDITIONAL PIECE TO -T MODEL JAW



There are several sizes of additional pieces available in stock made from aluminium and steel.

*Machine to match the shape of your workpiece*

### PULL-DOWN SET

### ROTATION STOPPER

### PROTECTION PLATES

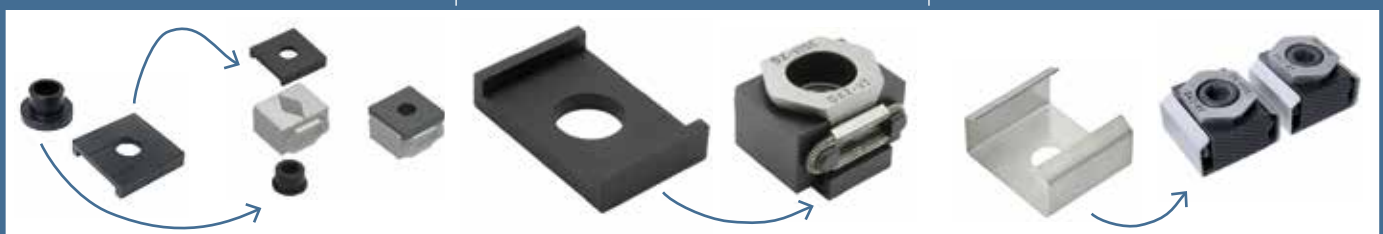

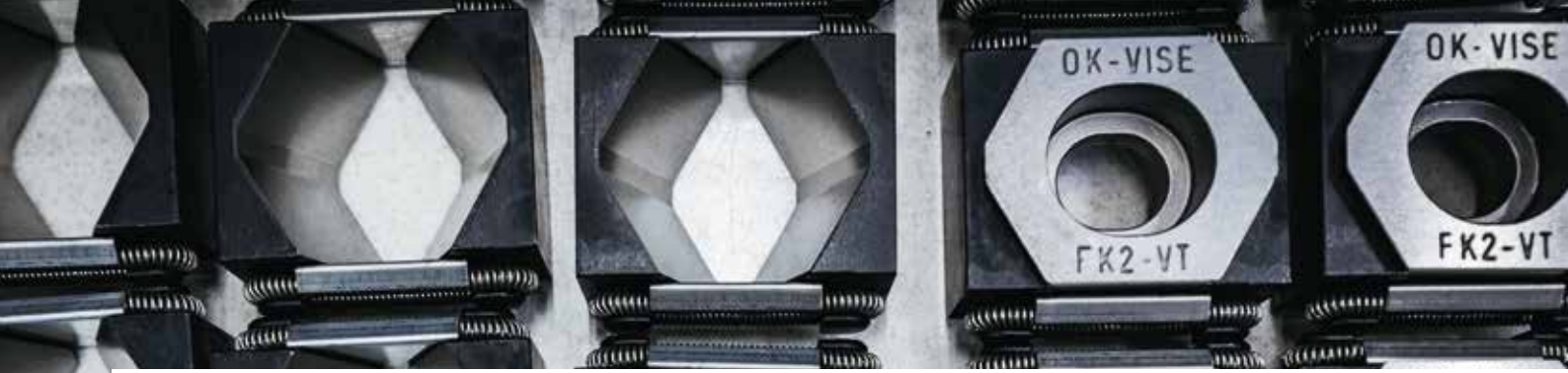

### Jaw combinations

All the different types of jaws can be combined with each other. For example, if you want one side of your low-profile clamp to have a smooth jaw and the other side to have a serrated one, that's possible!



You can find more information about the combo models here.

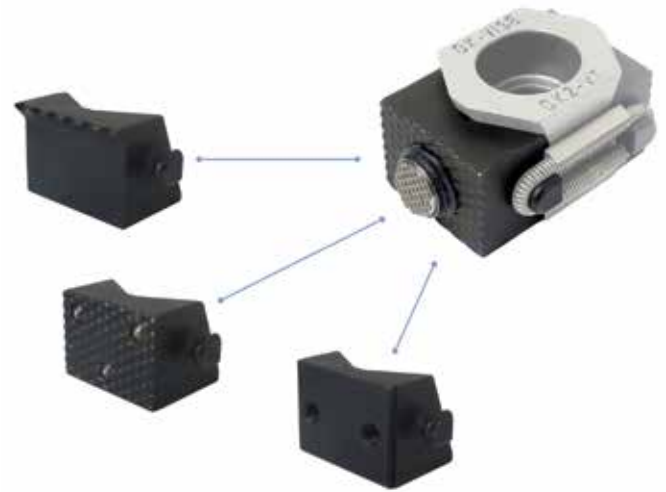

### OK-VISE Clamp Models

SIZE	A	B	D	D (inch)	F
Serrated version		BK2-VT	DK2-VT	DK2-VTI	FK2-VT
Smooth version		BK2-VT-S	DK2-VT-S	DK2-VTI-S	FK2-VT-S
Tungsten model	AK2-VT-DO	BK2-VT-D	DK2-VT-D	DK2-VTI-D	FK2-VT-D
Knife edge grip model		BK2-VT-G	DK2-VT-G	DK2-VTI-G	
Pin grip model		BK2-VT-G3	DK2-VT-G3	DK2-VTI-G3	FK2-VT-G3
Additional piece model		BK2-VT-T	DK2-VT-T	DK2-VTI-T	FK2-VT-T
Self-adjustable model		BK2-VT-E	DK2-VT-E	DK2-VTI-E	
Machinable model		BK2-VT+3	DK2-VT+5	DK2-VTI+5	FK2-VT+5
V-slot crossed model		BK2-VT-C	DK2-VT-C	DK2-VTI-C	FK2-VT-C
Single wedge pull-down, serrated		BK2-VT-PD	DK2-VT-PD	DK2-VTI-PD	FK2-VT-PD
Double wedge pull-down, serrated			DK2-WT	DK2-WTI	FK2-WT
Double wedge pull-down, smooth			DK2-WT-S	DK2-WTI-S	FK2-WT-S
Stainless steel model		BK2-VT-SS			
Economy-series, serrated		BK2-VT-O			
Economy-series, smooth	AK2-VT-SO	BK2-VT-SO			
Metric bolt	M5	M8	M12		M16
Imperial bolt	3/16"	5/16"		1/2"	5/8"
Force up to (kN)	10	25	90	90	150

## Low Profile clamps - Product codes

When ordering clamps with jaw combinations (combo models), simply add the short code of both jaws at the end of the product code: BK2-VT-XX.

Size	Jaw type	
<b>DK2 - VTI - S</b>		
A	I = Inch model	Empty or R = Serrated
B		S = Smooth
D		D = Tungsten
F		G = Knife edge
		G 1/2/3 = Pin grip ( 1 / 2 / 3 )
		T = Additional piece
		B = Adjusting and smooth
		E = Adjusting
		+ X = Machinable
		C = V-Slot crossed



## OK-VICE Clamp forces

Horizontal forces of OK-VICE Low-Profile Clamps

### B-SERIES

- BK2-VT+3
- - BK2-VT

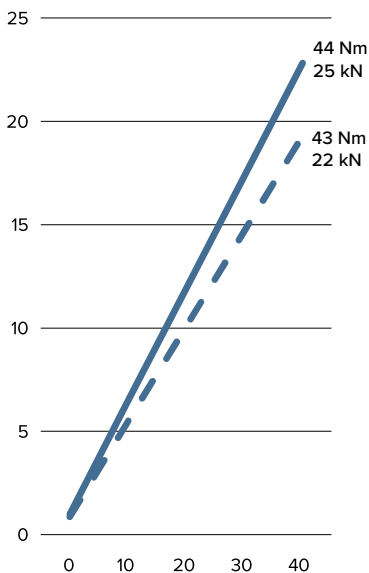

### D-SERIES

- DK2-VT
- - DK2-VT+5
- DK2-WT

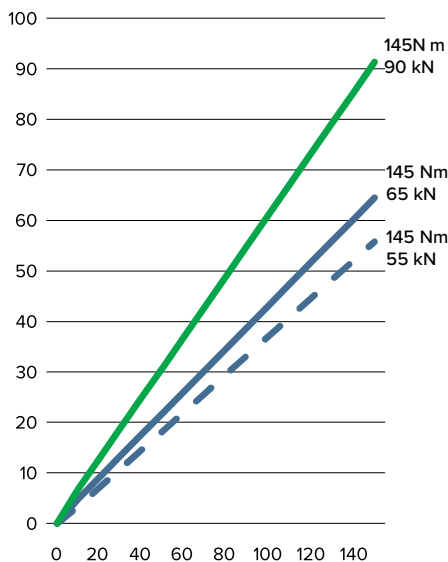

### F-SERIES

- FK2-VT
- - FK2-VT+5
- FK2-WT-S

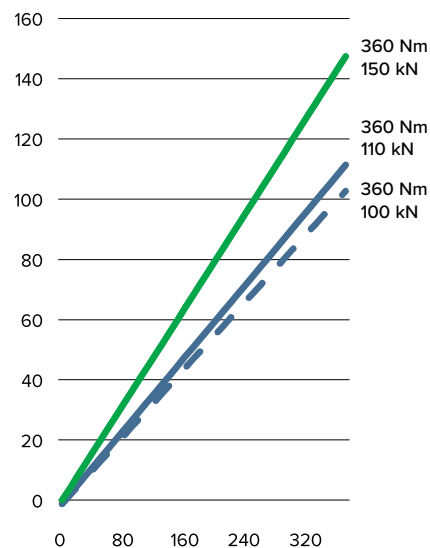

# OK-VISE® MULTI-RAIL SYSTEM



**Reduce setup time and streamline manufacturing processes with the OK-VISE® Multi-Rail System**

The Multi-Rail System is a simple way to build high precision modular fixtures, adapting effortlessly to various workpiece sizes. Its components can be quickly and easily reused and reconfigured for a multitude of applications and workpieces, meaning lower costs in fixtures and more flexibility in production!

## Some of Multi-Rail System components

- Rail
- Clamp modules
- Stop modules
- Parallel
- Side guide
- Floating modules

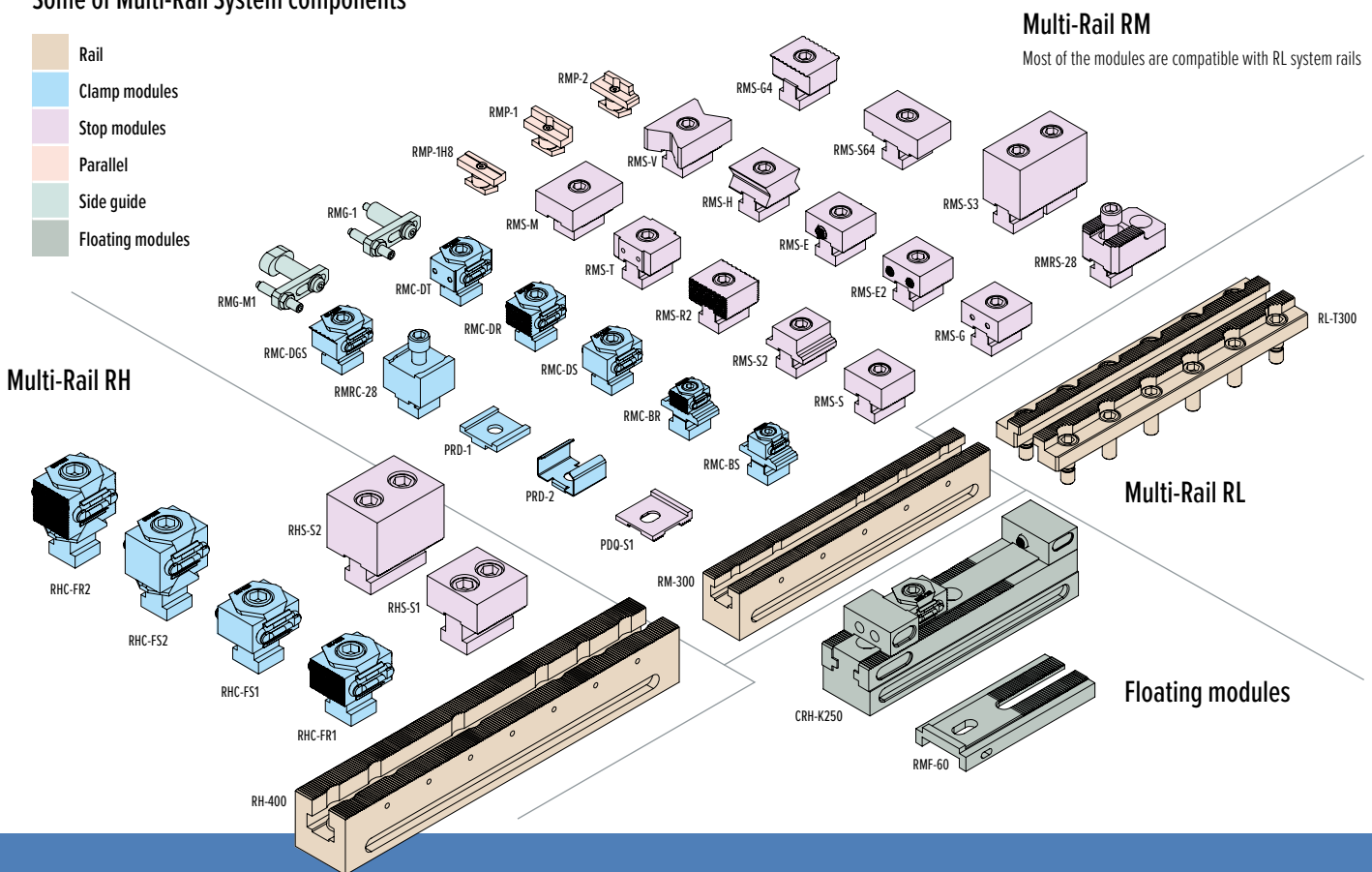

## QUICK AND EASY MODULAR RAIL SYSTEM WITH EXTREME ACCURACY

Find all modules and their specifications here:



[www.ok-vise.com/modular-workholding/](http://www.ok-vise.com/modular-workholding/)

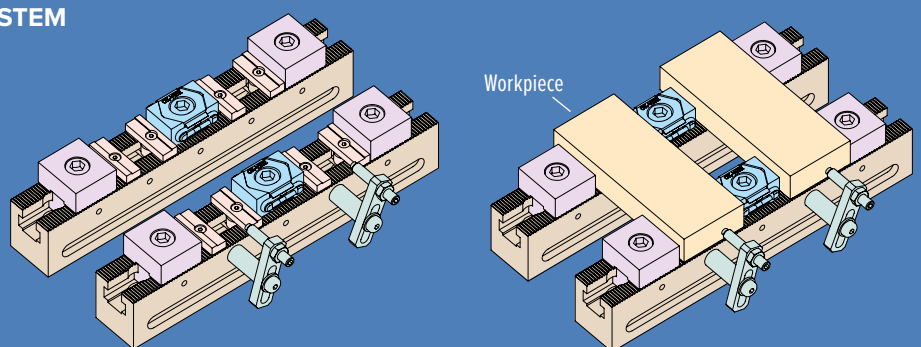

The picture shows the basic modules: Rails, clamps, stoppers, riser blocks and side guides

**Rail lengths  
up to  
850 mm**

*All rounder!*

*Maximize  
the workspace!*

*For heavy use!*

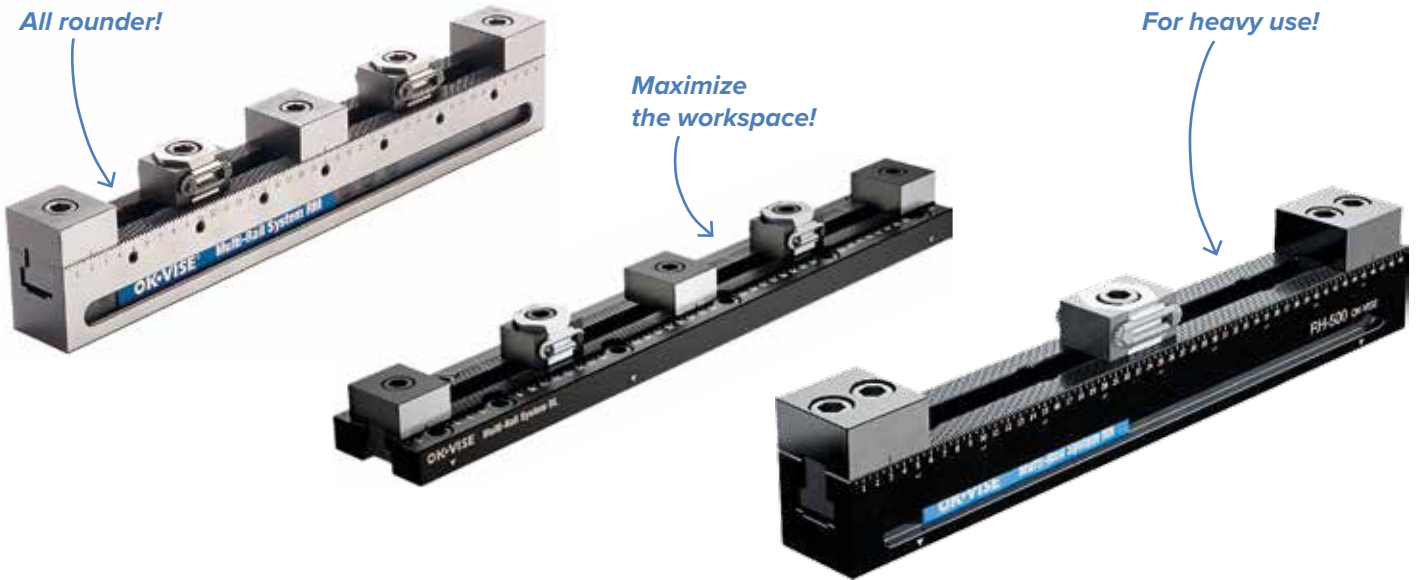

**MULTI-RAIL RM**

Compatible clamp series: **B- and D-series**  
 Installation bolt: **M12**  
 Max clamping force: **60 kN**  
 Height of the base rail: **50 mm**  
 Rail lengths: **100–850 mm**

**MULTI-RAIL RL**

Compatible clamp series: **B- and D-series**  
 Installation bolt: **M12**  
 Max clamping force: **60 kN**  
 Height of the base rail: **25 mm**  
 Rail lengths: **100–700 mm**

**MULTI-RAIL RH**

Compatible clamp series: **F-series**  
 Installation bolt: **M16**  
 Max clamping force: **100 kN**  
 Height of the base rail: **60 mm**  
 Rail lengths: **400–850 mm**

**All machining platforms**

The Multi-Rail System adapts to all possible workholding platforms like T-slot, blank, and grid platform. The size is selectable from three different categories: low, medium, and high.



**GRID**

**T-SLOT**

**BLANK**



## Why modular rail system?

- **Flexibility:** Easy adjustments and reconfigurations for various workpieces and production requirements. Existing modules can be used to create new setups swiftly.
- **Cost-effectiveness:** Proved to be more cost-effective in the long run than traditional fixtures due to the reusability and adaptability. The components are usually available from stock, ensuring fast acquiring of new.
- **Scalability:** Easily scale up your production. A modular fixture system can adapt effortlessly to new requirements simply by adding or adjusting components.

## Why OK-VICE Multi-Rail System?

- Enables three-directional machining, so for most workpieces a maximum of two set-ups are only required
- Multiple workpieces can be clamped simultaneously
- Can be used in all types of machining centers
- There are a wide selection of module types available, so a multitude of various workpieces can be clamped
- Repeatability of the fixturing set-up is simple and guaranteed by the most accurate rail system on the market
- Length up to 850 mm is available
- Extremely stable rail system due to its steep serration profile

## Good to know

### JAW OPTIONS AND COMBINATIONS

All the low-profile clamp jaw surfaces (page 13) are available with both the clamp and stop modules of the Multi-Rail System. Additionally, various combinations of these options are available for versatile use.

### MODULE COMPATIBILITIES

The RM and RL systems are intentionally designed to be highly compatible with each other. The majority of RM modules are compatible with RL System rails.

The RH system, however, utilizes its own clamp module (F series) and its own stoppers, although certain fundamental modules, such as side guides, can be shared between systems. For more detailed information on compatibility between different modules, you can refer to [ok-vise.com/modular-workholding](http://ok-vise.com/modular-workholding).

# MULTI-RAIL RM Applications

## SRM-300-DS1S2

Code	Name	pcs
RM 300	300 mm base rail	1
RMS-S	stop module (smooth)	2
RMC-DS	clamp module (smooth)	1

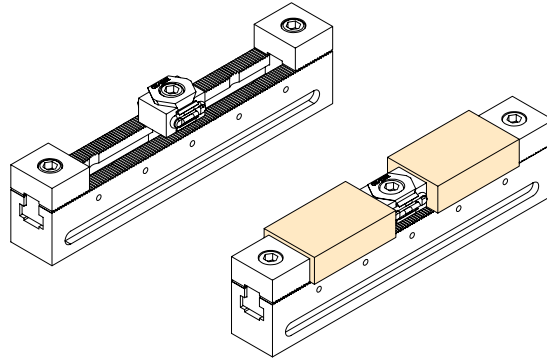

## SRM-500-DS2S3

Code	Name	pcs
RM-500	500 mm base rail	1
RMS-S	stop module (smooth)	3
RMC-DS	clamp module (smooth)	2

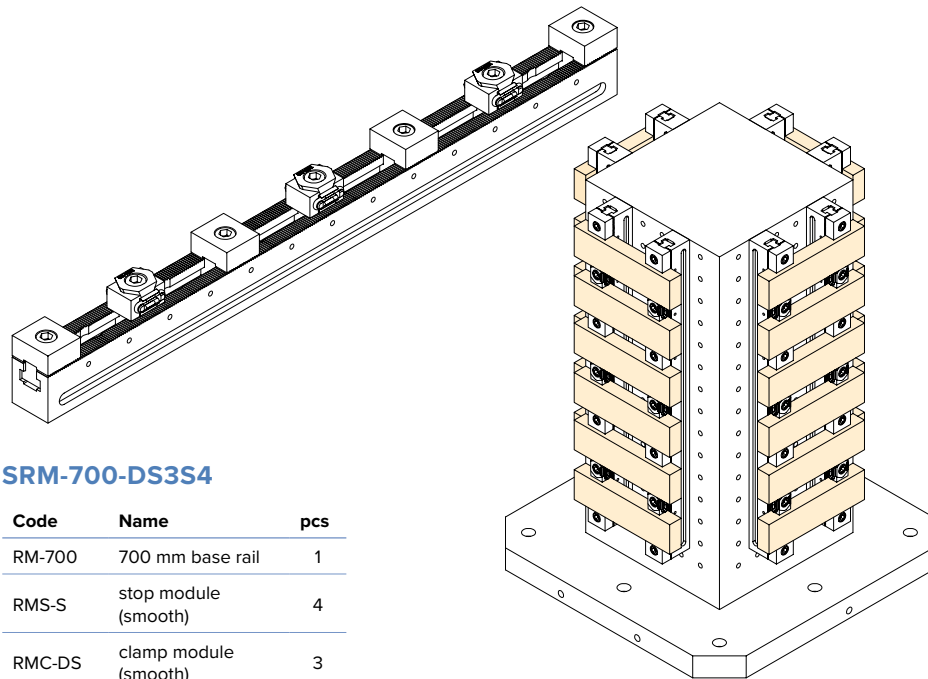
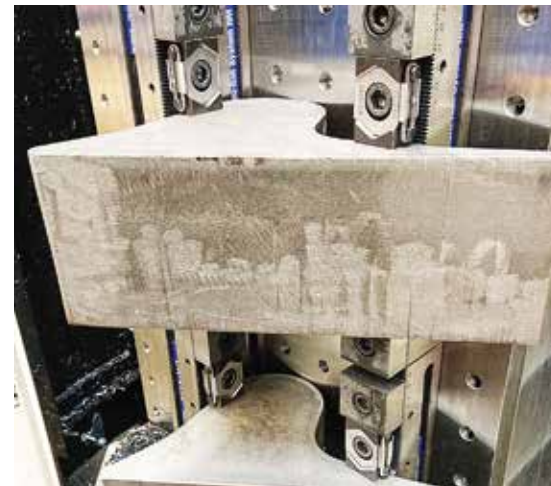
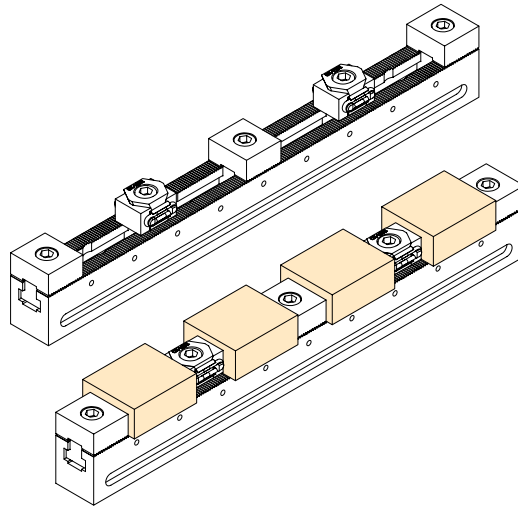

## SRM-700-DS3S4

Code	Name	pcs
RM-700	700 mm base rail	1
RMS-S	stop module (smooth)	4
RMC-DS	clamp module (smooth)	3



# MULTI-RAIL RM

## Applications

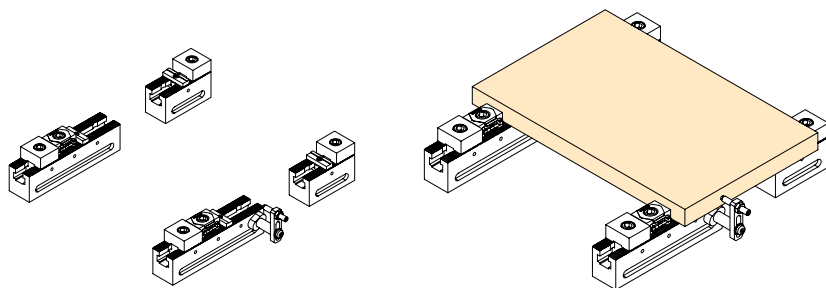

### SRM-4C4GD1-1

Code	Name	pcs
RM-200	base rail	2
RM-100	base rail	2
RMS-S	stop module (smooth)	4
RMC-DS	clamp module (smooth)	2
RMP-1	t-slot parallel	4
RMG-M1	magnetic side guide	1

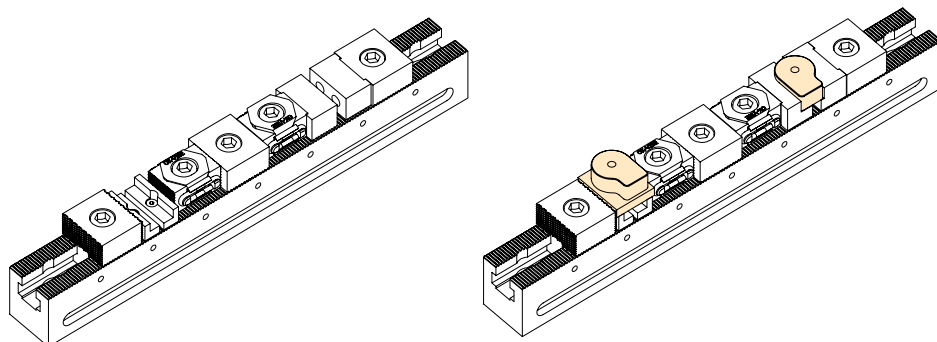

### SRM-Z107

Code	Name	pcs
RM-400	base rail	1
RMS-TS	stop module (additional piece)	1
RMC-DTS	clamp module (additional piece)	1
RMC-DR	clamp module (serrated)	1
RMS-S	stop module (smooth)	1
RMP-1	t-slot parallel	2
RMS-R2	stop module (serrated)	1
JDA-15	additional piece	2



# MULTI-RAIL RL

## Applications

### SRLT-300-DS1S2

Code	Name	pcs
RL-T300	base rail	1
RMS-S	stop module (smooth)	2
RMC-DS	clamp module (smooth)	1

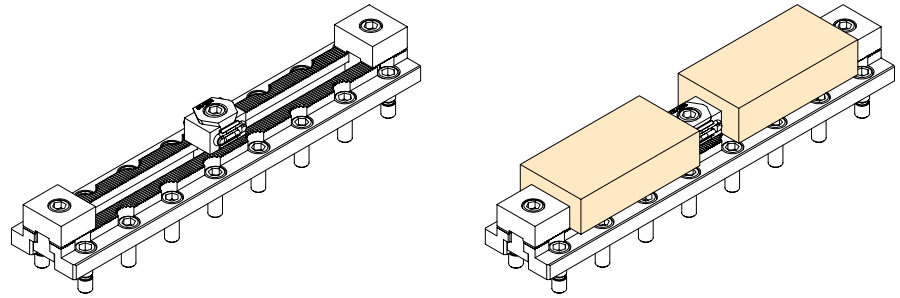

### SRLA-4C4GD1

Code	Name	pcs
RL-A210	base rail	4
RMS-S	stop module (smooth)	4
RMC-DS	clamp module (smooth)	2

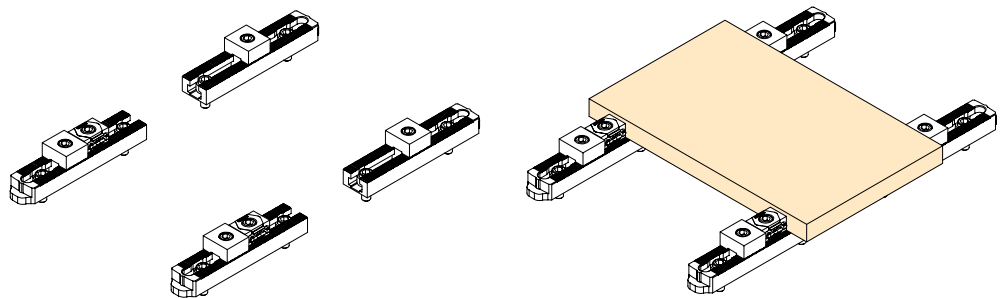

# MULTI-RAIL RH

## Applications

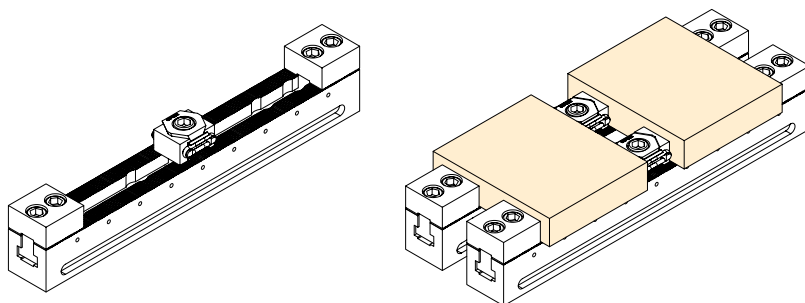

### SRH-500-FS1S2

Code	Name	pcs
RH-500	base rail	1
RHS-S1	stop module (smooth)	2
RHC-FS1	clamp module (smooth)	1

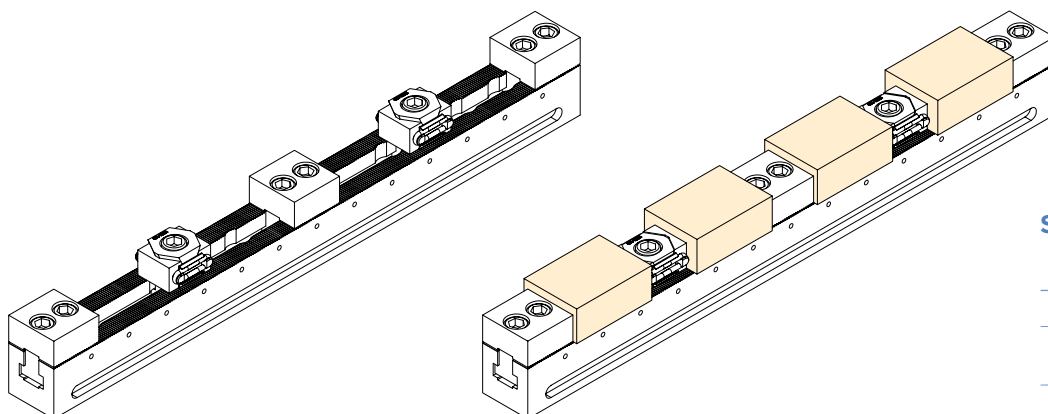

### SRH-700-FS2S3

Code	Name	pcs
RH-700	base rail	1
RHS-S1	stop module (smooth)	3
RHC-FS1	clamp module (smooth)	2



# FLOATING UNITS

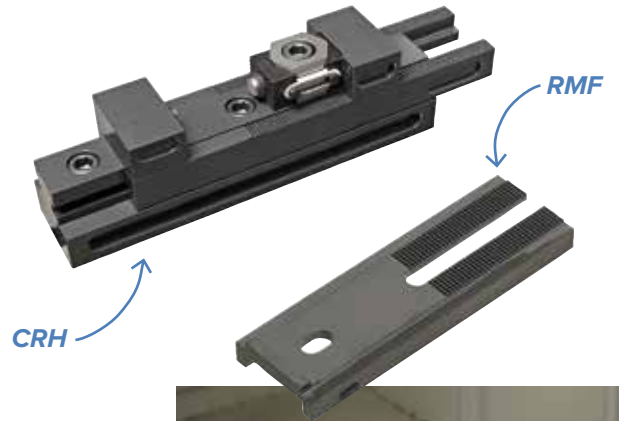

## OK-VISE CRH and RMF Units

CRM and RMF units are optimized for applications that require work support in floating mode, which means that once positioned, the unit clamps the workpiece in place without moving it. This is used when the workpiece is positioned by other means and bending of the workpiece at the support point needs to be avoided. Combo-Rail unit also features several centralizing mode and machine vise mode in addition to the floating mode.

## CRH Unit - The Combo-Rail

CRH Unit can be combined with most OK-VISE Fixturing Concept components. Especially, combining Combo-Rail units with Multi-Rail has been proven to be a brilliant combination. It's designed to be at the same height as the RM size rail, which helps implementing the CRH unit effectively. This unit can also be used in centralizing- and machine vise mode.

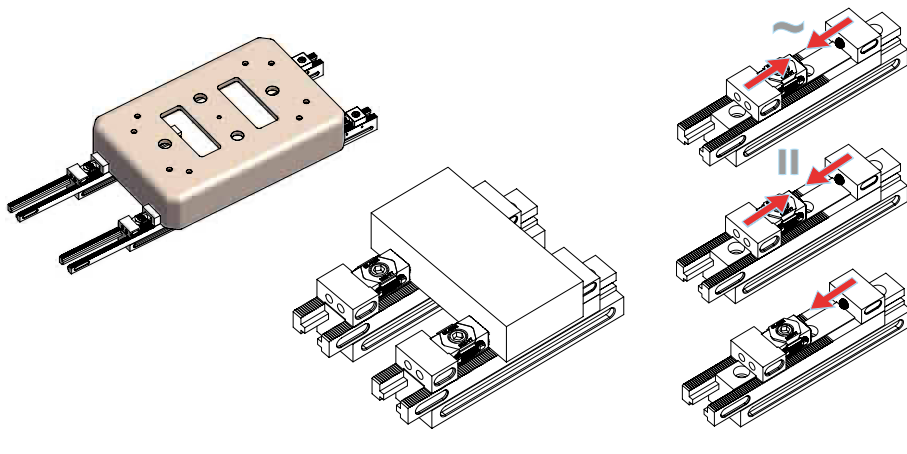

## RMF Unit

The RMF Unit is designed to offer easy floating functionality directly onto the rail using just one separate component. It has been developed to enhance compatibility with Multi-Rail System clamp and stop modules. Additionally, it enables the floating feature to automated applications and RL size rails.

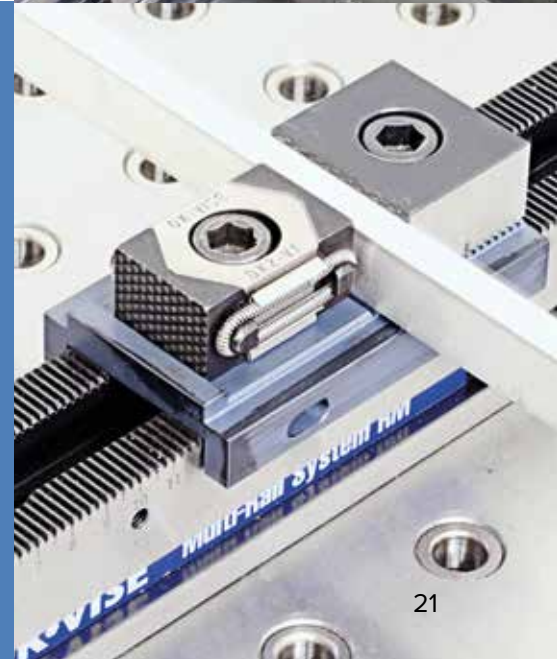
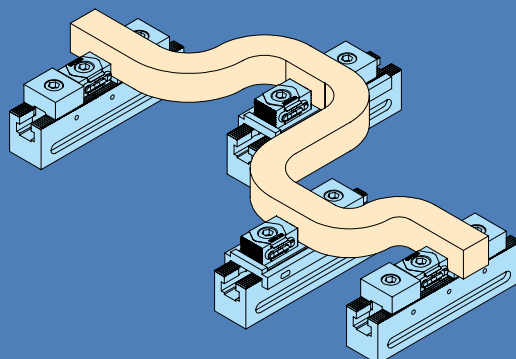

# OK-VISE® GRID SYSTEM

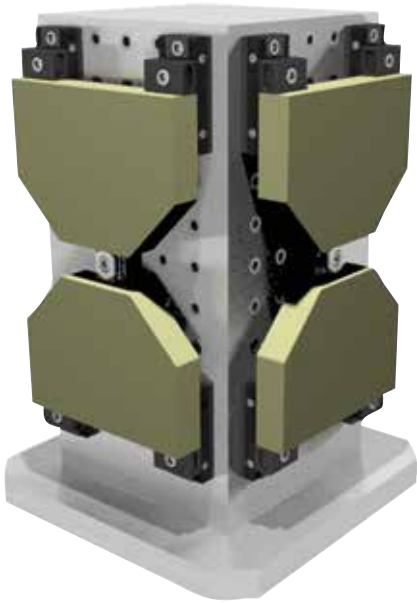

**Combines elevation, clamping, and stoppers into modular units for easy adaptability and quick adjustments**

It is perfect for securing complex workpieces such as plates, its versatility ensures precise positioning and stability, boosting machining accuracy and productivity. The base has a height of 25mm, making it ideal for clamping large workpieces within a limited machining area. The clamp, stopper and base rail are integrated into a single unit.

The module interface is designed for grid platforms (with 12mm positioning bushing and an M12 thread in a 50x50mm matrix).

## Grid System components

- Clamp modules
- Stop modules
- Parallel

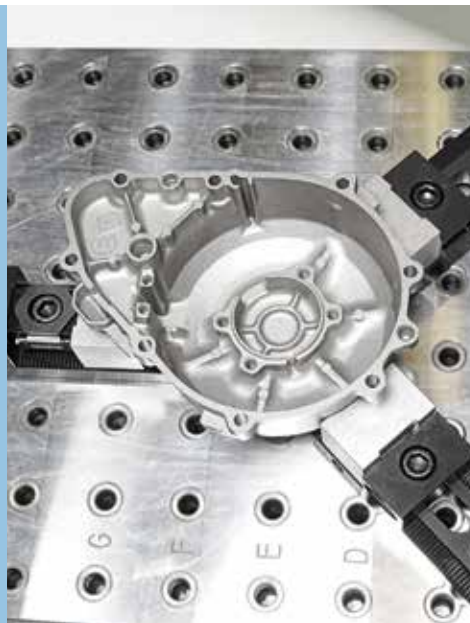
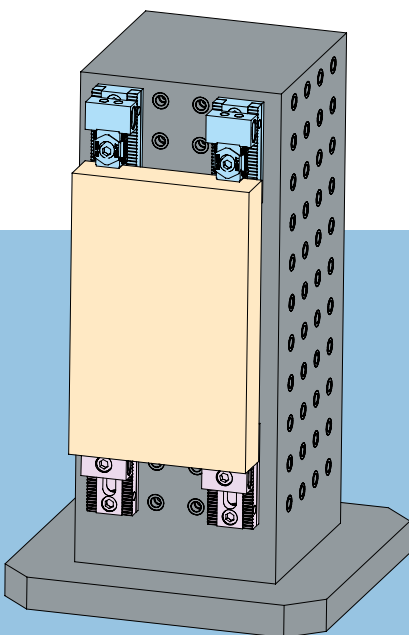
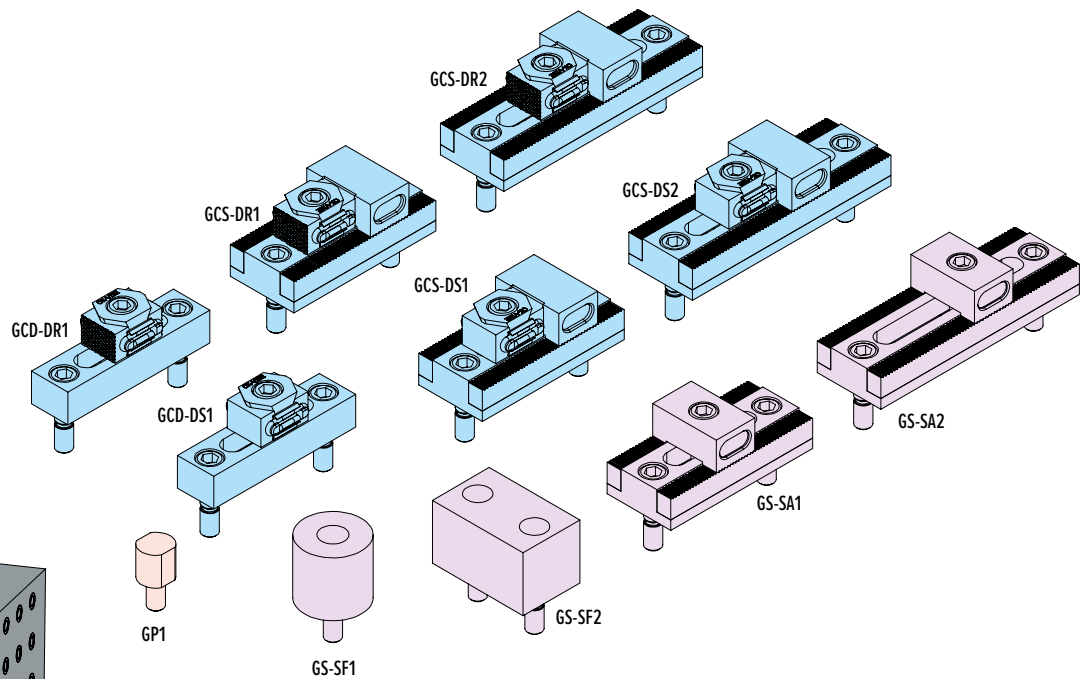

# OK-VISE® BLANK SYSTEM



## Versatile and efficient solution for production when specialized fixtures are needed

The system is based on the use of blank plates, such as aluminum or steel, which serve as a platform to build the fixture with a selection of clamp modules, stopper modules, and other components to accommodate different fixturing needs. Even if modular fixtures are increasingly popular, for workpieces with complex shapes or when large volumes of same shaped workpieces are machined the Blank System is still a valid option.

### Blank System components

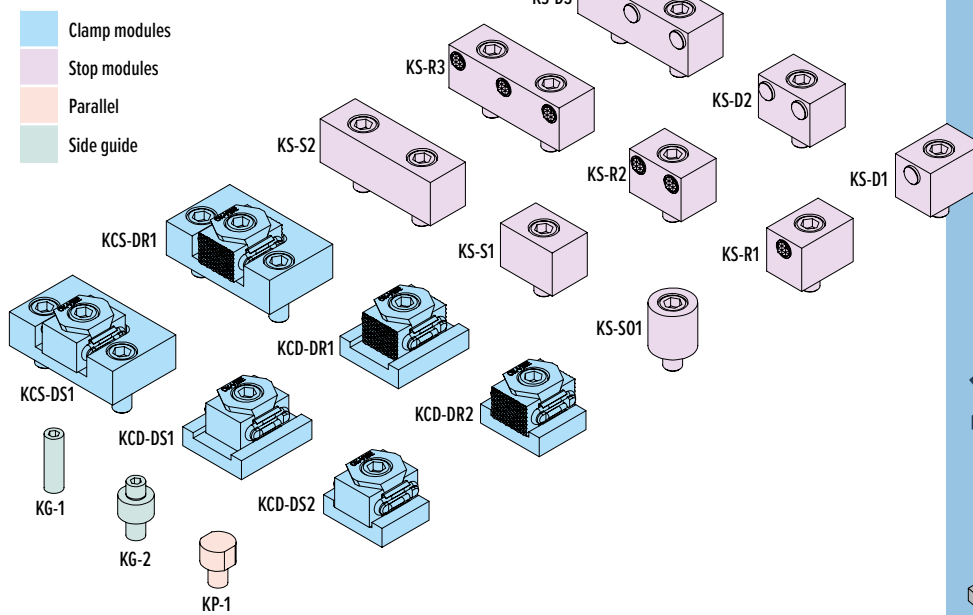

## How does OK-VISE Blank System works?

**1** SUBPLATE: You can either machine the subplate yourself or send us the parameters and we send you the ready-made machined plate.

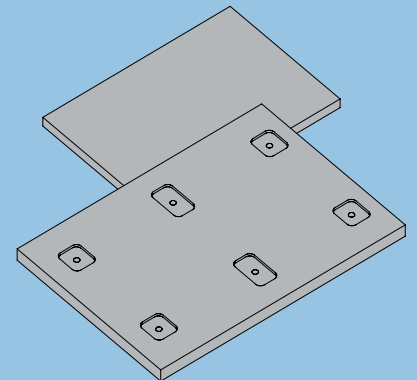

**2** Insert the fixture modules

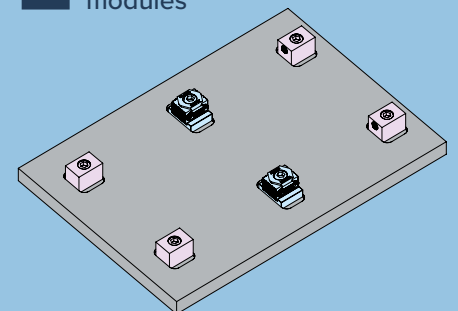

**3** Clamp the workpiece(s)

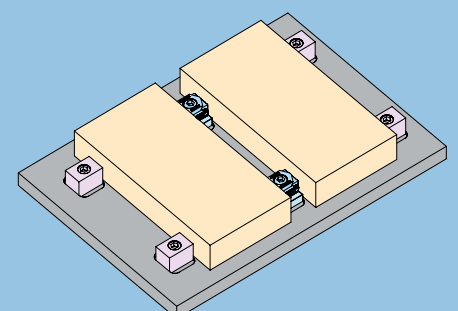

# Tips for building the OK-VISE fixture!

In general, the fixture can use force-closure or form-closure to hold a workpiece. In form-closure, the stopper modules and clamp modules create a shape that prevents the workpiece from moving — at least in some directions. More common is force-closure, where the workpiece is held — in some directions — by friction created by the clamping force.

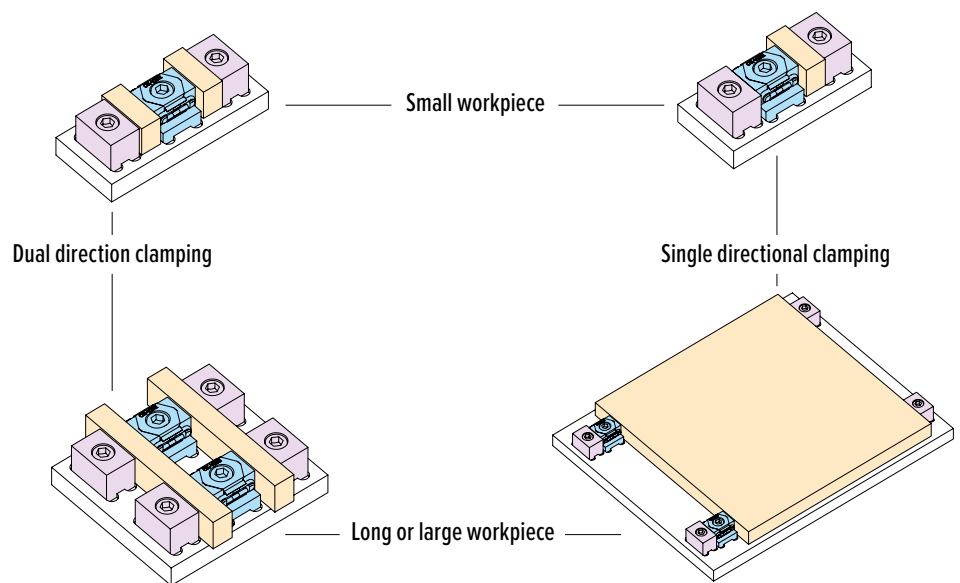

*OK-VISE clamping method and some typical installations.*

## 1 Starting the fixture design

In most cases the simplest way is to sketch a first fixture using OK-VISE clamp and stopper modules, adding remaining locating components like rise blocks and side guides later.

## 2 Friction

The greater the required friction, the higher the risk of leaving marks. OK-VISE offers a wide selection of jaw types for clamps and stoppers, ranging from smooth jaws to serrated and tungsten-carbide coated jaws, and finally to grip jaws that penetrate into the workpiece

## 3 Optimization

Even when using modular components, OK-VISE Fixturing Concept offers plenty of possibilities to finetune your fixture setup based on your machining strategies, workholding platform or any other relevant parameter.

# Modular vs. dedicated fixturing

In most cases machining a workpiece requires more than one fixture. The fixture for a specific workpiece and a specific machining operation can be built by using modules for modular fixturing or dedicated fixturing.

**A dedicated** (workpiece-specific) fixture is a great option when aiming to optimize the fixture solution for a specific workpiece. On the other hand, **a modular** fixturing system offers flexibility and reconfigurability.

## Multi-Rail System

Standardized components that can be easily assembled and disassembled

Off-the shelf availability of modules

Great for multiple workpiece clamping

Possible modifications can be limited to individual modules

Flexible and easy to adjust for different workpieces

## Blank System

Standardized components that can be easily assembled and disassembled

Off-the shelf availability of modules

Great for single workpiece clamping with odd-shaped workpieces

Fixture can be easily optimized by any relevant criteria

Setup change must be done by changing the fixture

## More material can be found on our website!

Explore our website for resources on machining fixturing, including industry news, product updates, partnership announcements, and details on upcoming industry events.

Discover fresh perspectives and stay informed about the latest developments shaping the industry.



[www.ok-vise.com/information-center/](http://www.ok-vise.com/information-center/)



# AUTOMATED CLAMPING

## Method of automated clamping

As the original inventor of the wedge-operated low-profile clamp, OK-VISE is offering also automated actuators that are optimized to utilize the well-known properties of the OK-VISE clamp: extreme clamping force in a small space combined with the high accuracy of the clamping force.

As an integral part of the OK-VISE Fixturing Concept, hydraulic actuators can be used to build truly modular fixtures.

Hydraulic clamping can be used in combination with

- Automated or manual workpiece loading
- Vertical or horizontal machining centers and 5-axis machines
- Live systems (continuous energy supply) or decoupled systems

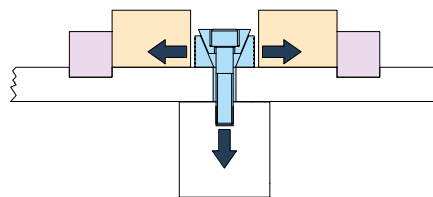

*PULL ACTUATION, instead of applying torque to the bolt, in most automated OK-VISE solutions pull actuation is used.*

## Hydraulic clamping

Compared to manual clamping, a system using hydraulic clamping has a consistent clamping force on the workpiece, clamping is faster and enables automated (robotic) loading of workpieces.

Compared to other hydraulic systems on the market, the OK-VISE modules

- Are based on the world renowned wedge clamp
- Prevents compression of hydraulic oil due to its wedge design thus eliminating vibration
- Create clamping force with a pull stroke
- Return stroke is performed by spring



*HA-Series actuators, designed for 350 bar pressure, which results in a compact size.*

## OK-VISE ELVA, Electrical clamping

OK-VISE ELVA ( Extra Low Voltage Actuation ) concept is multi-purpose, resulting in a design which enables maximum flexibility in automation. Now OK-VISE is launching the next step in the evolution of automated workholding. ELVA has been designed to be fully compatible with OK-VISE's Fixturing Concept. ELVA stands for Extra Low Voltage Actuation ensuring easy and risk free installations.

## Decoupling of power supply

The core component is ELVA actuator, which does not need to be connected to power supply while machining. So power supply ( Load Station Unit ) can be decoupled easily and efficiently. This is especially useful in pallet changers, pallet pools and FMS systems.



Watch video about ELVA-electrical clamping system here:

[www.ok-vise.com/product-category/automated-clamping/electrical-clamping/](http://www.ok-vise.com/product-category/automated-clamping/electrical-clamping/)

## Why should I consider ELVA System for my automated fixture system?

- Easy to use
- Simple plug & play automation
- Need for special expertise is avoided
- Mechanical locking leads to reliable clamping
- Quick to install
- Rapid ramp-up
- Economical: Safe and clean energy supply
- Cost efficient decoupling of power supply

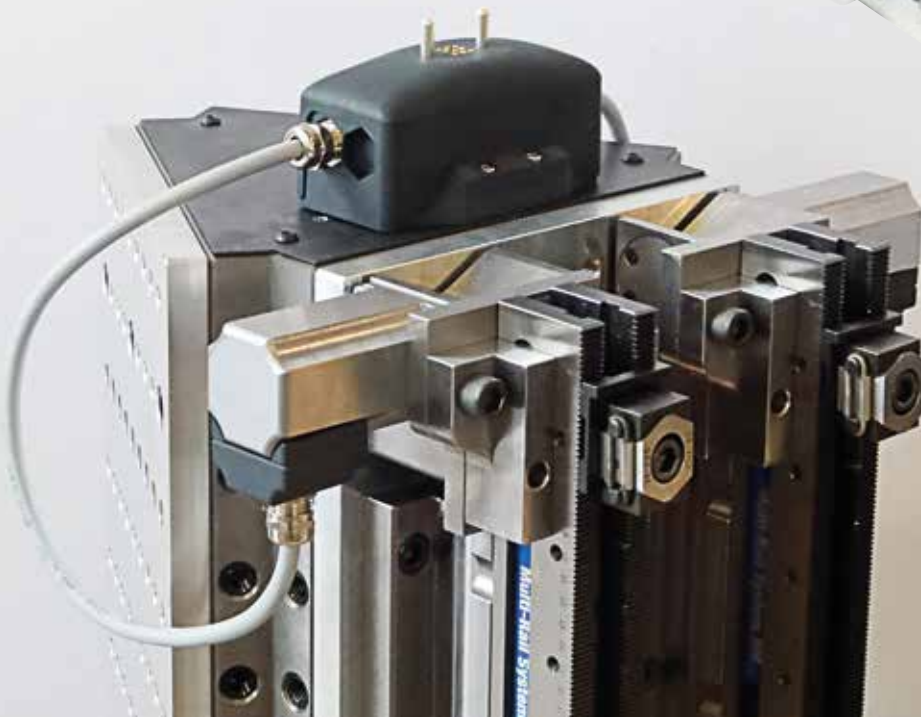

# TOOLING BLOCKS

Several types of the workholding platforms for workholding operations are offered by OK-VISE through its global distribution network. OK-LOCK zero-point positioning system, RPS trunnion units and tooling blocks are some of workholding platforms used in the OK-VISE projects.

By choosing a suitable workholding platform speed of setup changes, stability, easy access of tooling and utilization of the machine envelope can be greatly improved.

OK-VISE tooling blocks of different shapes and sizes are typically used in horizontal machining centers (HMC). In vertical machining centers (VMC), OK-LOCK units and indexers with trunnion units like RPS are typical workholding platforms.

The tooling block concepts offered by OK-VISE Oy provide the state-of-the-art features that support effective and efficient fixturing enabling higher productivity of the CNC system.



# OK-LOCK ZERO-POINT SYSTEM

OK-LOCK is OK-VISE's zero-point positioning system that is used for holding sub-plates and workpieces.

OK-LOCK is operated by admitting compressed air (6 bar) into the positioning modules setting them to a release position, in which sub-plates can be inserted or removed easily.

Examples of the OK-LOCK positioning elements application

- Integrated in tooling blocks
- On the machine table of the vertical machining centres
- Integrated fourth axis
- Fastening the fourth axis in the trunnion unit such as RPS
- Use of spigots to clamp the workpiece directly



# COMPANY

## The early days

In the early 1980s Finnish entrepreneur and inventor *Olli Kytölä* ("OK") bought his first NC machining centers. Soon he became frustrated with the large size and small clamping force of machine vises and other workholding systems then available on the market for his brand-new machines.

Once, when hanging laundry at home, he started thinking whether some sort of device similar to the screw anchor he used for attaching the clothesline to the brick wall could also be used in fixturing. His main goal was to achieve a high and accurate clamping force with a small device. The rest, as they say, is history – OK-VISE low-profile clamps had been born.



*Some of the first generation clamps.*



*Some of the latest products*

OK-VISE was founded in 1984 and it is located in Muurame, Central Finland.

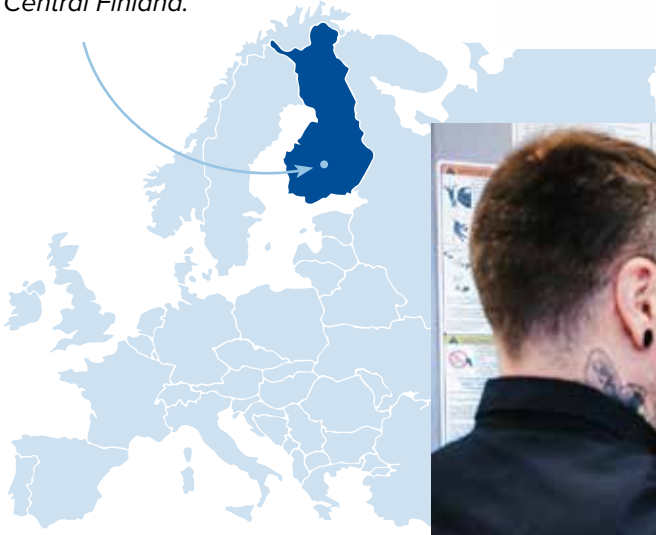

## OK-VISE today

Today our products are available through a global distribution network. We are proud to ensure that even the most remote locations can be served within a few working days.

OK-VISE Oy has grown into one of the most respected players in the industry due to its long-term work based on customer satisfaction and product quality. We still operate in Muurame, Central Finland, and we want to continue to be a part of the development of the local industry.

Our product family has grown since the early days and from the low-profile clamp. The biggest reasons for this have been the changing needs of the manufacturing industry and the increasing interest in modular fixturing methods. In fact, our strongest assets are based on excellent product expertise and market awareness, which help us bring more new innovations to the industry.

We are dedicated to ensuring that, regardless of the workpiece to be clamped, our offered components provide you with a quick, safe, and effortless solution for fixture applications, making it easier than ever before.

## Don't stay alone with your fixturing challenges

Helping customers and designing fixtures is something we do on a daily basis.

Ensuring the most effective way to keep your workpieces clamped is a priority for us. Our team of experts is dedicated to providing comprehensive assistance, ensuring that every customer, whether a part of our international sales network or an end user, receives the support they require.

If you have any questions, concerns or custom requirements, our technical support team is ready to assist you. Don't hesitate to contact us.

- ✓ **Fixture sketches**
- ✓ **Installation advice**
- ✓ **Customization support**
- ✓ **Application support**
- ✓ **Product information**

Technical support:  
[support@ok-vise.com](mailto:support@ok-vise.com)



# OK-VISE® FIXTURING CONCEPT

## Modular and dedicated fixture solutions

### All Platforms - All Workpieces



MADE IN  
FINLAND

OK-VISE offers workholding solutions to meet the growing and evolving demands of modern manufacturing. Our services and expertise ensure effective solutions, delivered through our international partner network.

OK-VISE fixturing components are known worldwide as core components of any modern workholding system. In the machining industry the OK-VISE stands for ultimate quality.

A wide selection of information as well as the latest updates about our products are easily obtained from our website at: [www.ok-vise.com](http://www.ok-vise.com)



Follow us on social media:

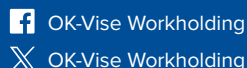
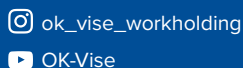

MANUFACTURER

DISTRIBUTOR

## OK-VISE®

OK-Vise Oy, P.O.Box 5  
40951 Muurame, Finland  
Tel. +358 20 7790 699

Technical questions: [support@ok-vise.com](mailto:support@ok-vise.com)  
[www.ok-vise.com](http://www.ok-vise.com)